

# MSP430F16x Processor

The jumpers on these two connectors allow the peripherals (RS-232, LEDs, 7-segment & pushbuttons) to be disconnected from the MSP430F16x.

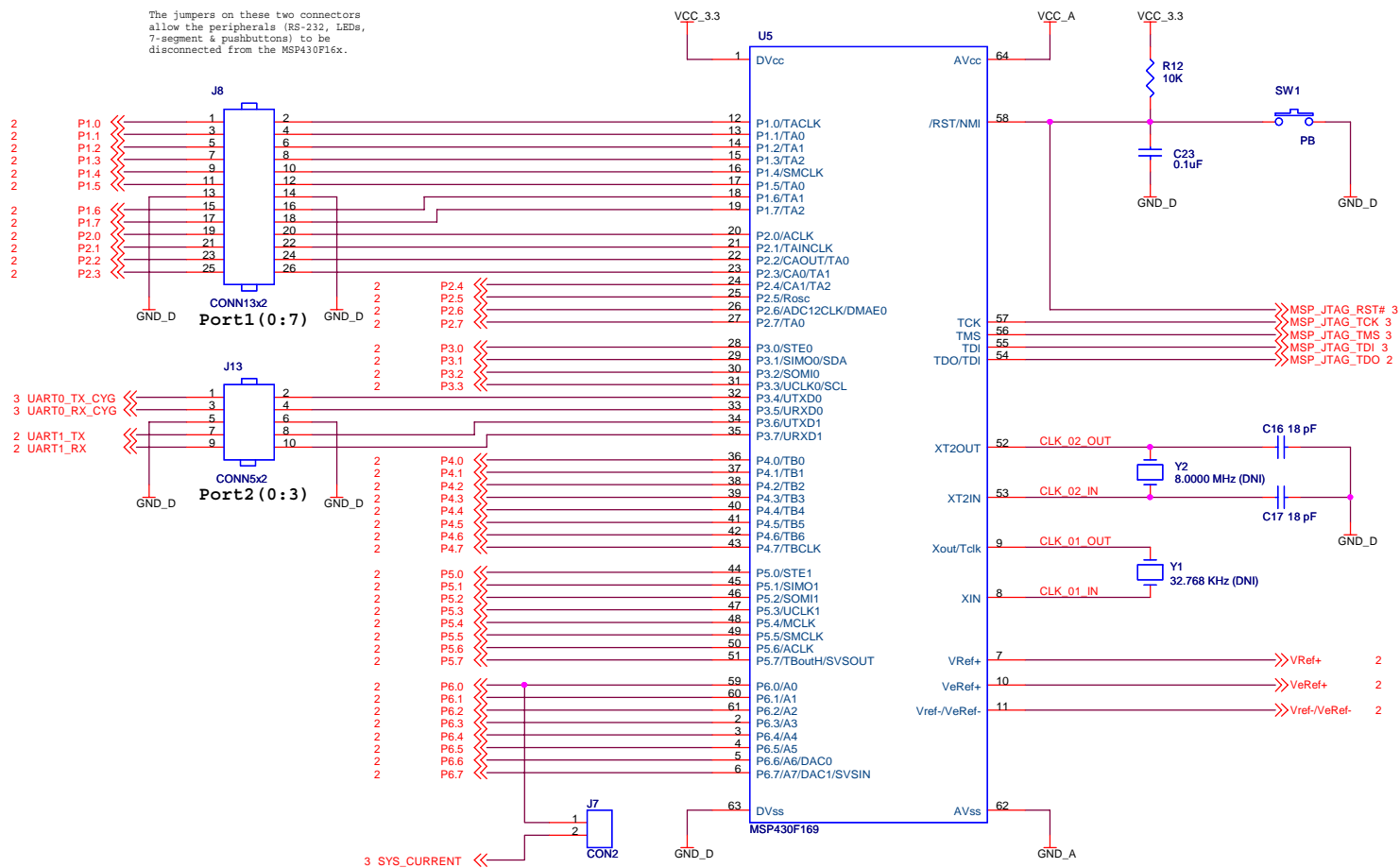

MSP430F16x Processor		
Size	Document Number	Rev
	MSP430F16x_LITE	x1
Date:	Wednesday, May 19, 2004	Sheet 1 of 4

# Pushbuttons, LEDs & 7-Segment Display

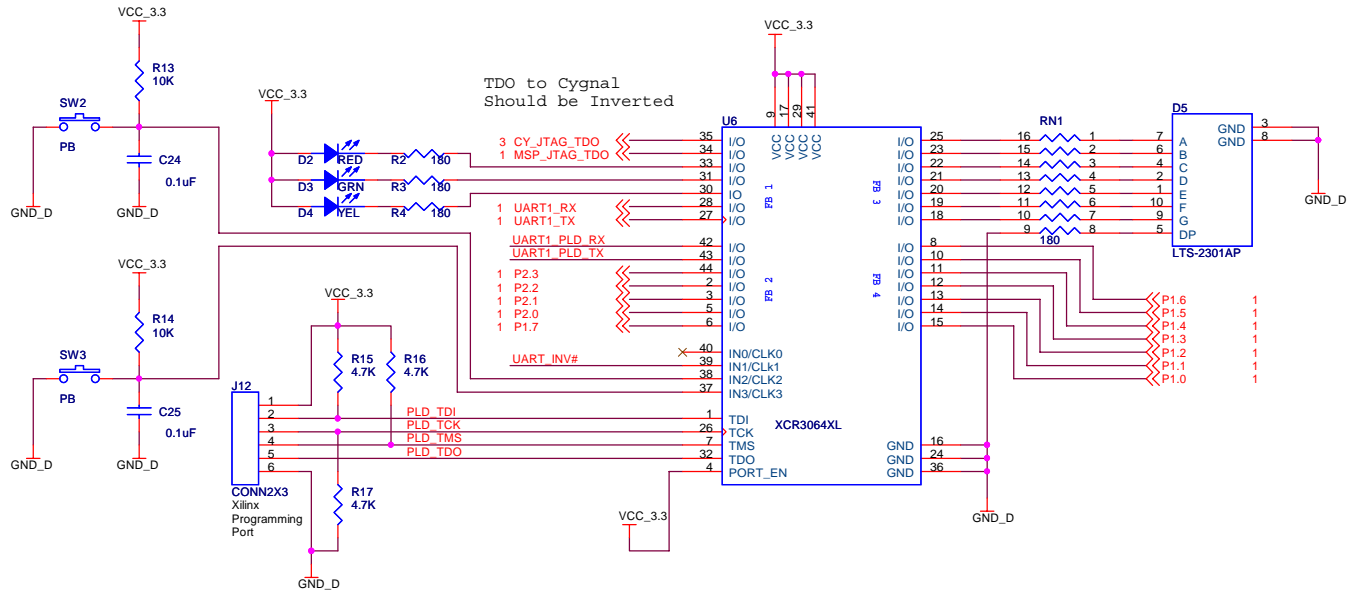

# GPIO Headers

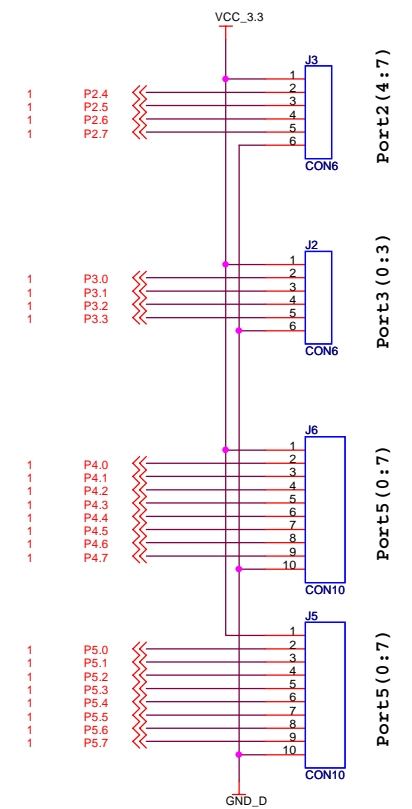

# RS-232

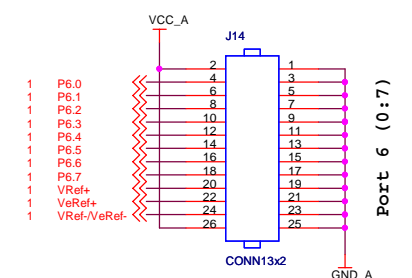
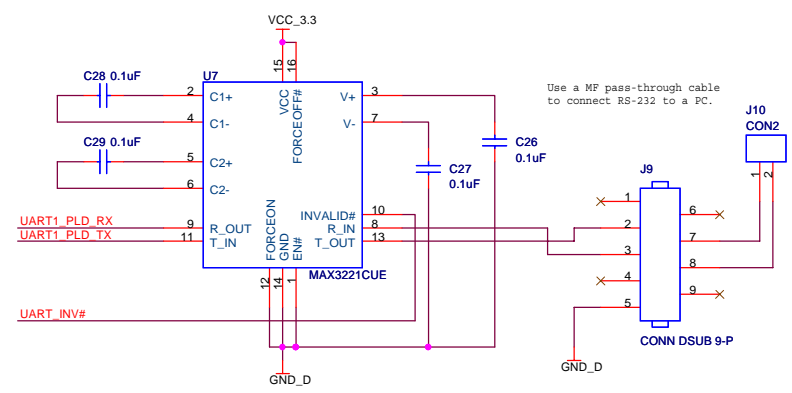

Peripherals & IO Headers		
Size	Document Number	Rev
	MSP430F16x_LITE	x1
Date:	Sunday, May 16, 2004	Sheet 2 of 4

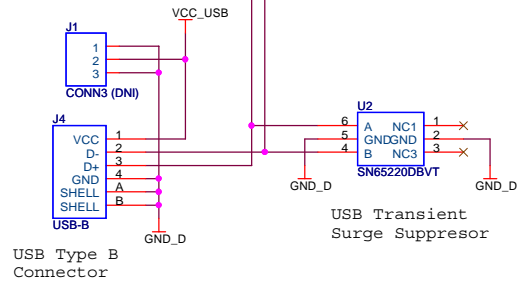
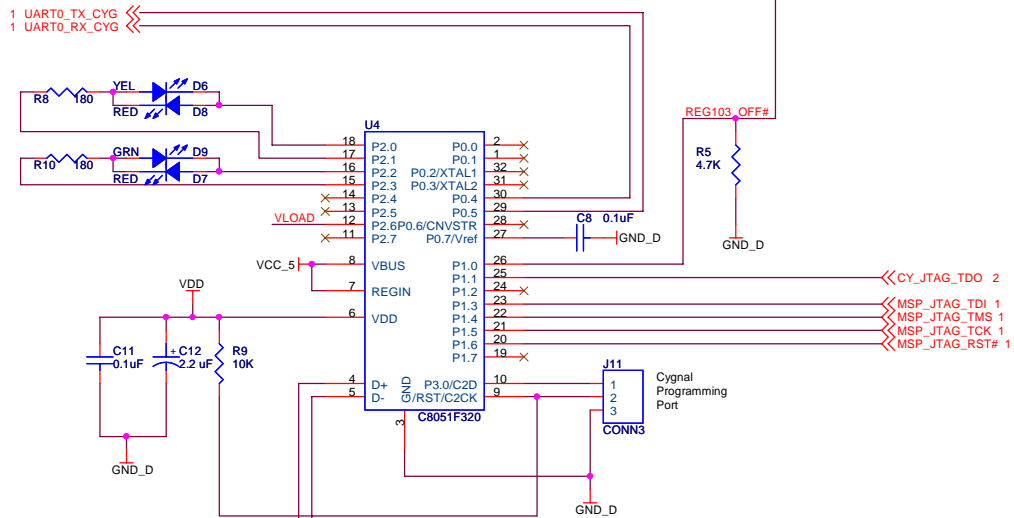
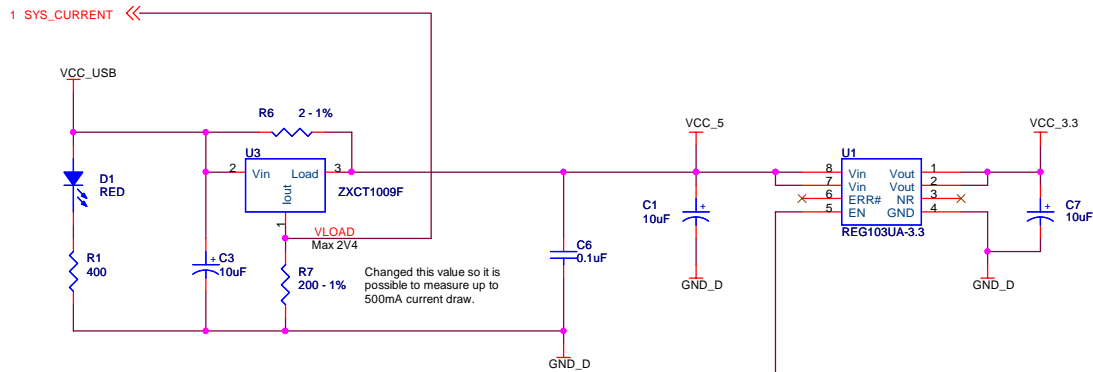

## Bulk Decoupling

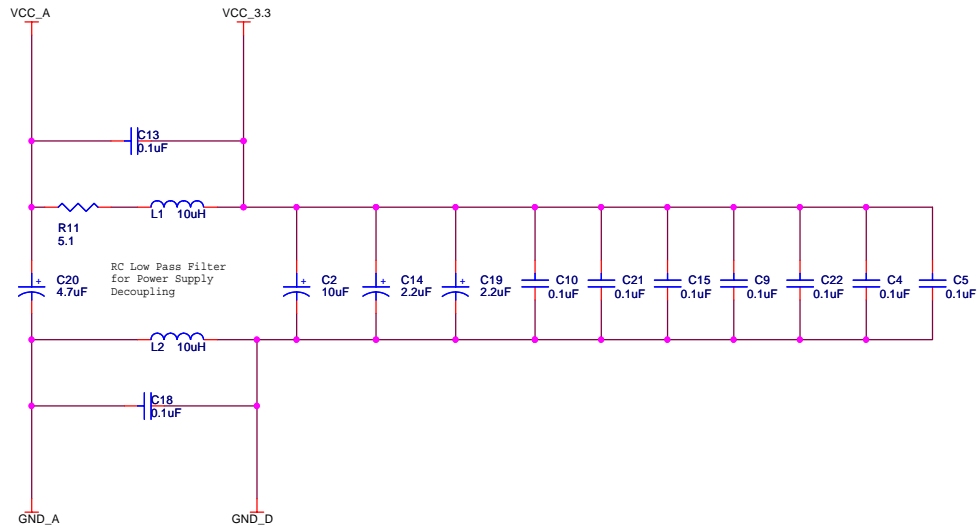

## Mechanical - Fiducials and other Mounting Holes

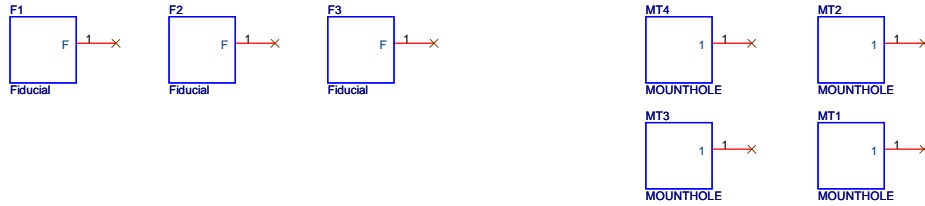

## Test Points

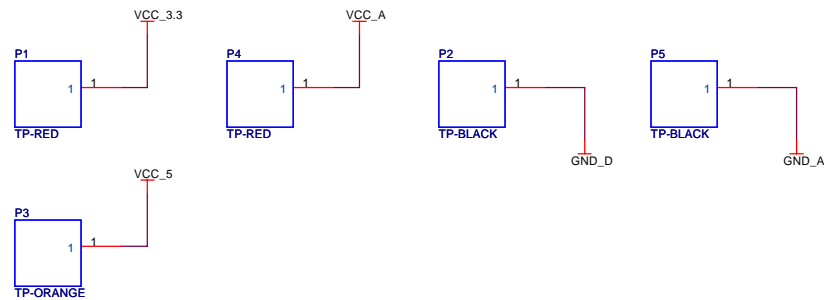

Decoupling & Mechanical		
Size	Document Number	Rev
	MSP430F16x_LITE	x1
Date:	Wednesday, May 19, 2004	Sheet 4 of 4